

Sash Fasteners

Traditional

Hardware

DIRECT

Fasteners for Optimum Performance

THD161 Brighton Fastener - Standard Non Locking

Finishes Available



Specification

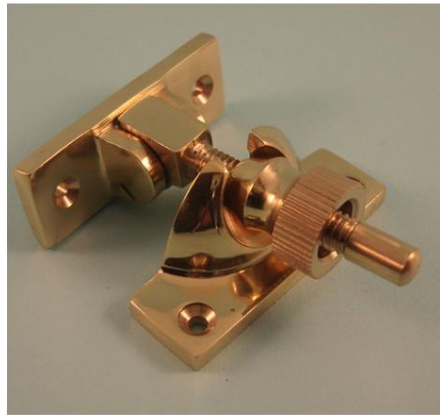

THD161

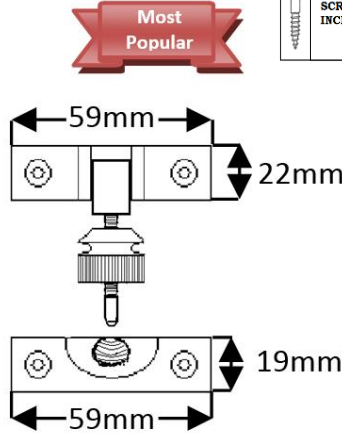

Material : Cast Brass
 Weight : 140 grams inc screws
 Size of Plate : 59mm x 22mm
 Height of Product : 70mm
 Sold as : Each
 With Screws : 4 Number 19mm x 4
 EB, Raised Head, Slotted,
 Countersunk, Steel Wood Screws
 Inner Box Quantity : 10
 Outer Box Quantity : 100

Part No.

THD161/PB
 THD161/CP
 THD161/SCP
 THD161/SCP
 THD161/AB
 THD161/AC
 THD161/AN
 THD161/BRO
 THD161/BLP

Description

Brighton Fastener – Standard – Non Locking
 Brighton Fastener – Standard – Non Locking
 Brighton Fastener – Standard – Non Locking
 Brighton Fastener – Standard – Non Locking
 Brighton Fastener – Standard – Non Locking
 Brighton Fastener – Standard – Non Locking
 Brighton Fastener – Standard – Non Locking
 Brighton Fastener – Standard – Non Locking
 Brighton Fastener – Standard – Non Locking
 Brighton Fastener – Standard – Non Locking
 Brighton Fastener – Standard – Non Locking

Finish

Polished Brass
 Chrome Plated
 Satin Chrome Plated
 Satin Nickel Plated
 Antique Brass
 Antique Copper
 Antique Nickel
 Bronze
 Black Polished

NOTE : This product is made from Cast Brass and manufactured using the Traditional Sand Cast method.

The items requiring a Lacquer protection are protected using the Electrophoretically Lacquered process giving a very attractive long-lasting product.

Traditional Hardware Direct will Guarantee the product against product failure due to manufacturing defects under normal usage for a period of 10 years from the date of purchase (for further information see our website).

When cleaning the product, use a cloth soaked in warm soapy water and dry off using clean dry cloth – Do not use any chemical cleaners as this will harm the product and will break down the lacquer and tarnish the product.

Due to the nature of the manufacturing process, a tolerance of + / - 5 % must be allowed on the weight and dimensions given on this product

For further information Call Sales on 01254 7739465 or visit our website : www.traditionalhardwaredirect.com