

POWERMATIC

R100 Controlled Door Closer

For the product DOP, see <https://concealddoorclosers.com>

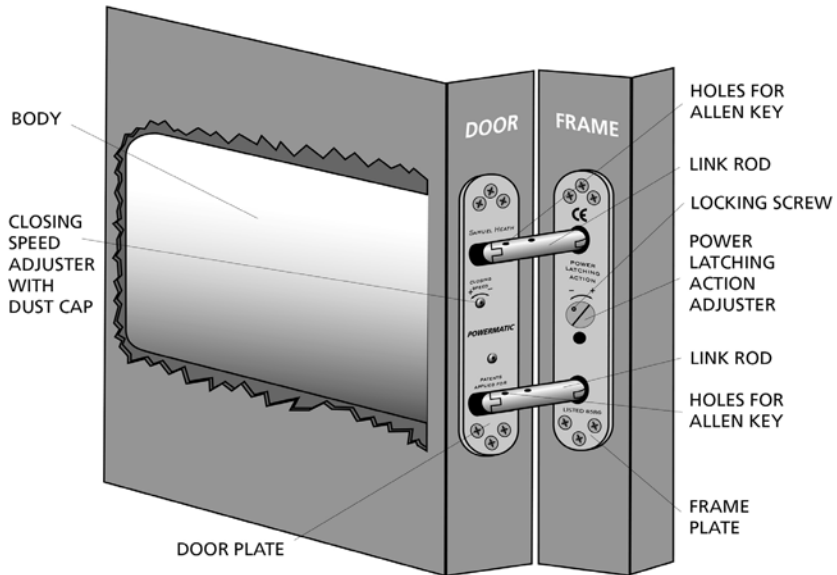

IF USING INTUMESCENT KIT R97-XX, REFER TO INSTRUCTIONS WITH KIT AS INSTALLATION DEPTHS WILL INCREASE

IMPORTANT NOTICE - FOR FIRE DOOR INSTALLATIONS REFER TO ITEM 1 IN FITTING INSTRUCTIONS







- UKCA marked
- CE marked and adjustable to conform to power size 3 of Controlled Door Closing Device. BS EN1154: 1997 (Test door 60kg/132lbs).
- 1 Hour Fire Test BS EN1634-1: 2000.
- Adjustable speed control.
- Adjustable power latching action.
- 1 ½ Pairs of hinges should be used in conjunction with this closer on all doors.
- Suitable for doors opening to a maximum of 105°. A door stop should be fitted.
- Maximum door weight 80kg/175lbs, width 950mm/38".
- Suitable for latched and unlatched doors.
- Should NOT be used with rising butt hinges.
- For use with concealed hinges contact our Customer Service Team - details on the back of this leaflet.

PLEASE READ FITTING INSTRUCTIONS THOROUGHLY BEFORE INSTALLATION

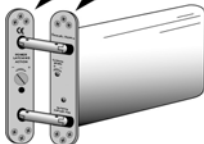
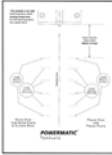
POWERMATIC

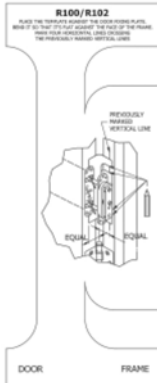
R100 Controlled Door Closer

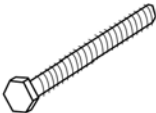
PARTS LIST

(A) Fixing Plates 	(B) 	(C) 	(G) 
Door Closer - x 1	Template - x 1	Allen Keys - x 2	
(D) 	(E) 	(F) 	
Screws - x 12	Extractor Bolt - x 1	Allen Key for Adjuster Screw (Locking) - x 1	Mortice Template - x 1

CHECK ALL COMPONENT PARTS AGAINST PARTS LIST.

TOOLS REQUIRED

- Screwdriver (Plain Slotted)
- Screwdriver (Phillips)
- Wood Chisel 25mm x 185mm / 1" x 7"
- Solid Centre Auger Bit or Spade Bits
26mm Ø and 28mm Ø
1 1/16" Ø and 1 1/8" Ø
- Bradawl
- Power Drill
- Tape Measure
- Pencil
- Adjustable Spanner
- Ruler

The use of a dedicated morticing tool is highly recommended for multiple installations. Mortice Template supplied.

Order code R98.XX

www.morticer.com

A DBB morticer, a long shaft and WB27 and WB29 cutters will be required

Eye Protectors, Ear Defenders and a Face Mask are recommended during installation of Powermatic®.

1 IMPORTANT NOTICE

DOOR CLOSERS FITTED TO A FIRE DOOR

- Powermatic®, conforms to Power Size 3 of Controlled Door Closing Device Standard BS EN1145:1997 when the power latching action is set to maximum.
- Turn adjuster screw fully to positive (+) as explained in 9.
- Closer must be fitted no more than 1000mm / 39" from floor and within 300mm / 12" of a hinge.
- Closer must be fitted no more than 800mm / 31 1/2" from the floor & within 300mm / 12" of a hinge on steel doors.
- Closer and plates should be bedded in either Alfacyrl FR Intumescent Acrylic Mastic R99-XX or alternatively Intumescent Kit R97-XX, both available from Samuel Heath.

2 TEMPLATE POSITIONING

- Ensure door is plumb, hinges are free, and that timber is sound.
- Take template provided and fold along centre line. Open door to 90°.
- Secure template to door edge and frame edge within 300mm / 12" of a hinge ensuring the centre line is central in line with the pivot point of the hinge.
- Draw a vertical line at the centre point of the door edge on the template.

Fig. 1

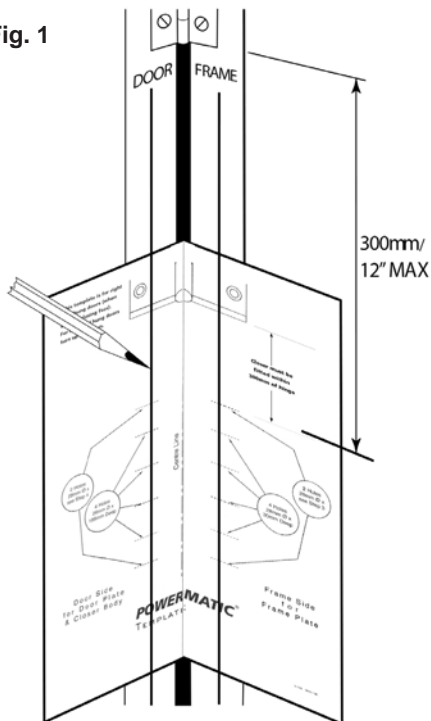

NB This line must not exceed 35mm / 1 3/8" from template centre line.
See Fig. 2

- Repeat this vertical line onto the frame side at the same distance from centre line.
- At each point on the template where the vertical lines cross the horizontal dotted lines mark through the template using an bradawl into the door edge and frame edge to establish drilling points.
- Remove template RETAIN FOR REFERENCE

NOTE: Door can now be removed from frame to assist drilling if preferred.

To achieve a maximum opening angle of 105° the centre of the closer must be no more than 35mm / 1 3/8" from the pivot point of the hinge.

Fig. 2

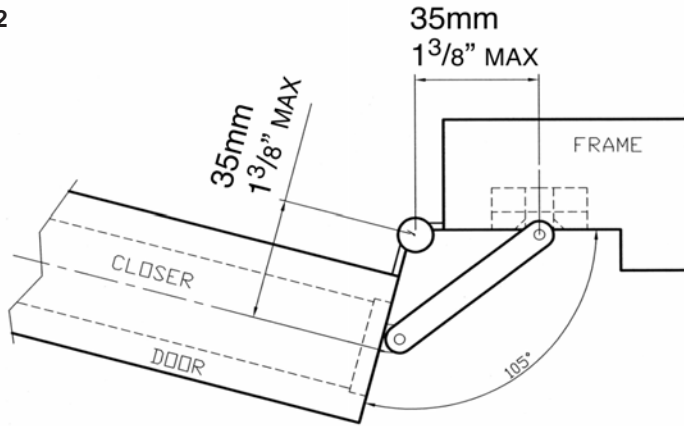

IMPORTANT

To ensure the 35mm / 1 3/8" distance is not exceeded the closer and fixing plate can both be offset in the door leaf and jamb (closer to the hinge pivot point) by up to a maximum of 6mm / 1/4" as illustrated below.

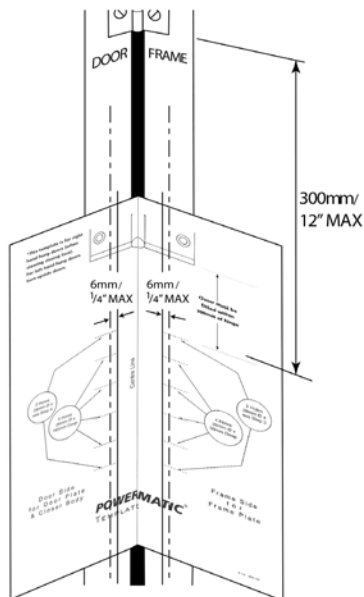

3 FRAME PREPARATION FOR FRAME PLATE

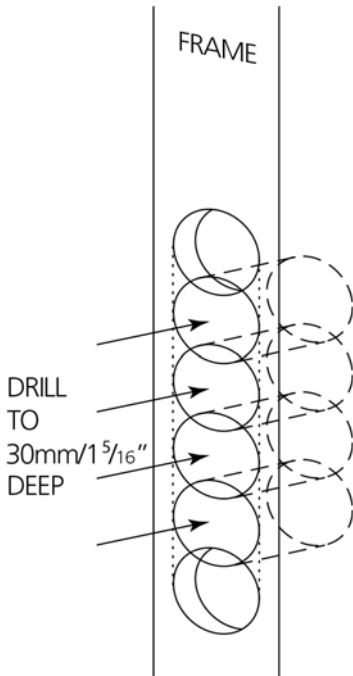

NB To ensure correct operation of closer there must be a 3mm / 1/8" gap between the two fixing plates when the door is in the closed position. These instructions are based on the gap between door and frame being 3mm ± 1.0mm

- Drill 4 x 28mm / 1 1/8" Ø holes x 30mm / 1 5/16" deep to accept frame plate assembly as indicated on template
- Drill 2 x 28mm / 1 1/8" Ø holes x 5mm deep to accept frame plate ends. *
- Remove excess timber between drilled holes to accommodate frame plate.

4 DOOR PREPARATION FOR BODY & DOOR PLATE

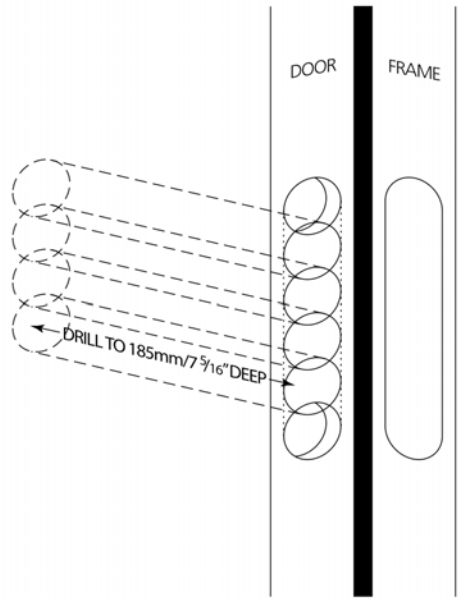

- Drill 4 x 26mm / 1 1/16" Ø x 185mm / 7 5/16" deep holes to accept closer body as indicated on template. *
- Drill 2 x 28mm / 1 1/8" Ø holes x 5mm to accept door plate ends. *
- Remove excess timber between drilled holes to accept the closer body and door plate.

*** IF USING INTUMESCENT KIT R97-XX, REFER TO INSTRUCTIONS WITH KIT AS INSTALLATION DEPTHS WILL INCREASE**

5 INSTALLING CLOSER

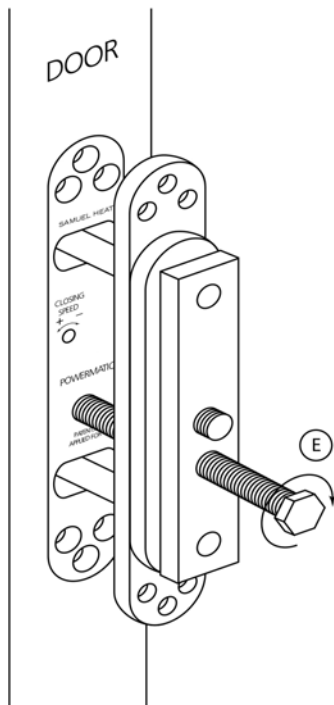

- Insert closer body into door.
- Insert extractor bolt (E) into position and rotate clockwise until holes in link rods appear.
- Generally for thicker doors expose both holes on each rod.

6

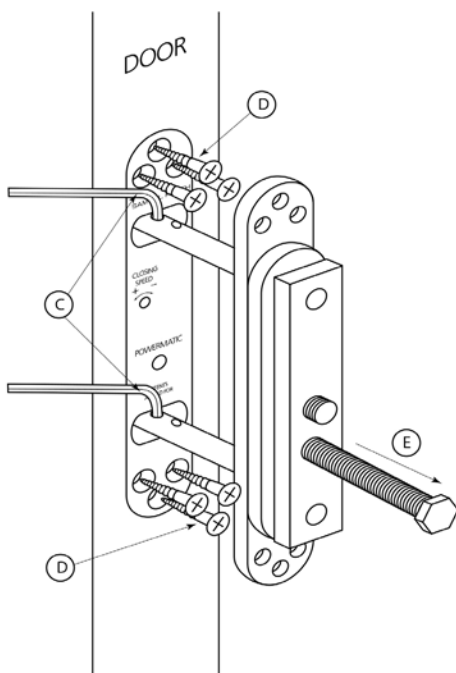

- Insert the Allen keys (C) through both top and bottom link rod holes.
Both Allen keys must be correctly located
- Remove extractor bolt.
- Secure door plate to door with six screws (D).

IMPORTANT
With composite doors and door linings it is essential to drill pilot holes $\text{Ø } \frac{3}{32}$ " (2.5mm) to suit fixing screws.

7

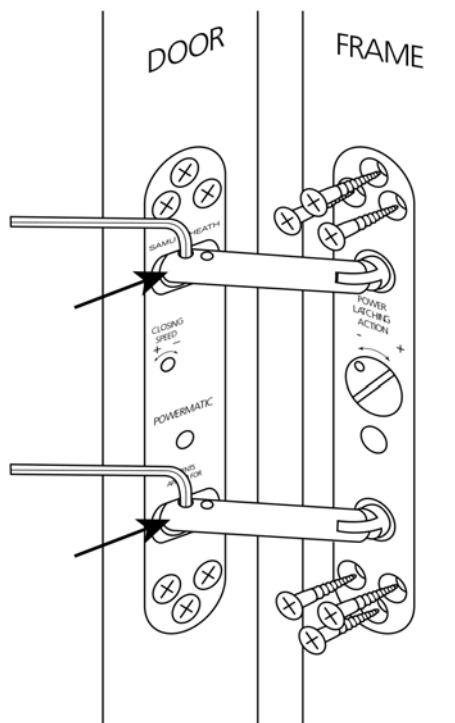

- With the closer secure and now held open by Allen keys, if necessary firmly push both link rods across door plate and offer frame plate into frame void. Secure with six screws (D).

- Open door slightly and remove Allen keys.

- Installation is now complete.

8

ADJUSTMENT - CLOSING SPEED

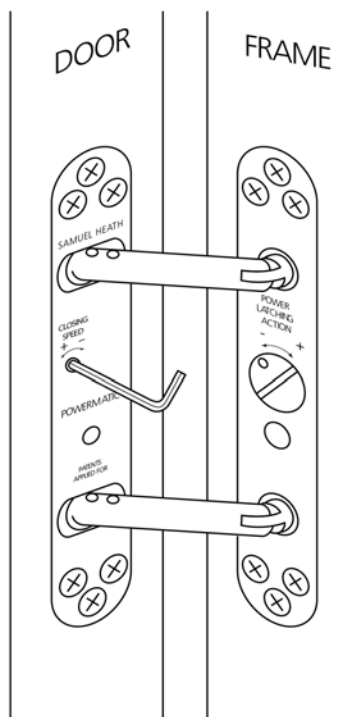

- Remove dust cap.

- Use one of the Allen keys (C) to adjust closing speed.

- Positive (+) increases door speed.

Negative (-) reduces door speed, as indicated on door plate.

9 ADJUSTMENT - POWER LATCHING ACTION

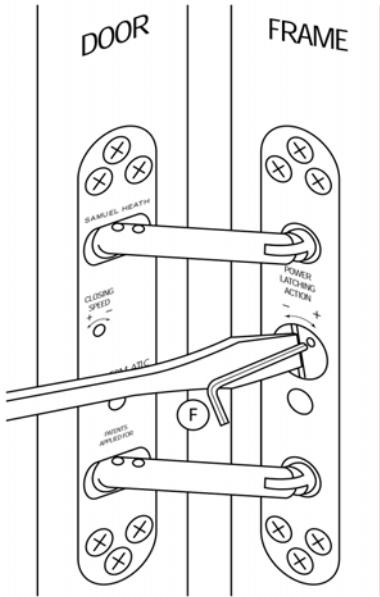

- The power latching action can be adjusted using a plain flat ended screwdriver.
- Loosen locking screw using Allen key (F) to allow the adjuster screw to turn.
- Positive (+) increases the angle at which latching action engages. Negative (-) decreases angle at which the latching action engages.
- Re-tighten locking screw when correct power latching action achieved.

The Powermatic is protected by the following Patents and Applications.

CANADA	2365822 2436363
HONG KONG	1038953
JAPAN	2000-602490
SINGAPORE	82862
TAIWAN	156554
USA	6625847 2004/0111831
UK	GB25447175 GB2415014 EP1605126

AUSTRIA
BELGIUM
DENMARK
FRANCE
GERMANY
IRELAND
ITALY
LUXEMBOURG
NETHERLANDS
SPAIN
SWEDEN
SWITZERLAND
LIECHTENSTEIN

EP1605126

MAINTENANCE

- Ensure that fixing screws remain tightly fastened.
- Ensure that all components on the doorset, i.e. latch, hinges etc. are functioning correctly.

Samuel Heath & Sons plc

Leopold Street
Birmingham
B12 0UJ, England

T: +44 (0)121 772 2303
F: +44 (0)121 772 3334
Sales Office Direct Line: +44 (0)121 766 4200

Info@samuel-heath.com
www.samuel-heath.co.uk

www.concealeddoorclosers.com

US Customer Service

usa@samuel-heath.com
Federal I.D. No. 58-1504682
www.samuel-heath.com

9-395

10/10/22

PS 8357